

1. WOOD STUD FRAMING
2. WALL SHEATHING
3. PLYWOOD DECK
4. 26 GAUGE GALVANIZED "L" METAL (BONDERIZED) (4" ABOVE FINISH SURFACE)
5. 2.5 GALVANIZED METAL LATH
6. GU80 BASE COAT
7. HD-250 BY PLI-DEK SYSTEM, INC. (PER SPECIFIED MIL THICKNESS CR, HR, OR PMA)
8. PROTECTION BOARD AND/OR PD DRAIN BOARD (AS SPECIFIED)
9. PMA-UV BY PLI-DEK SYSTEM, INC. (VERTICAL FACE OF GALVANIZED "L" METAL)
10. ASTM C-920 POLYURETHANE SEALANT

**DETAIL D**

SCALE: N.T.S.

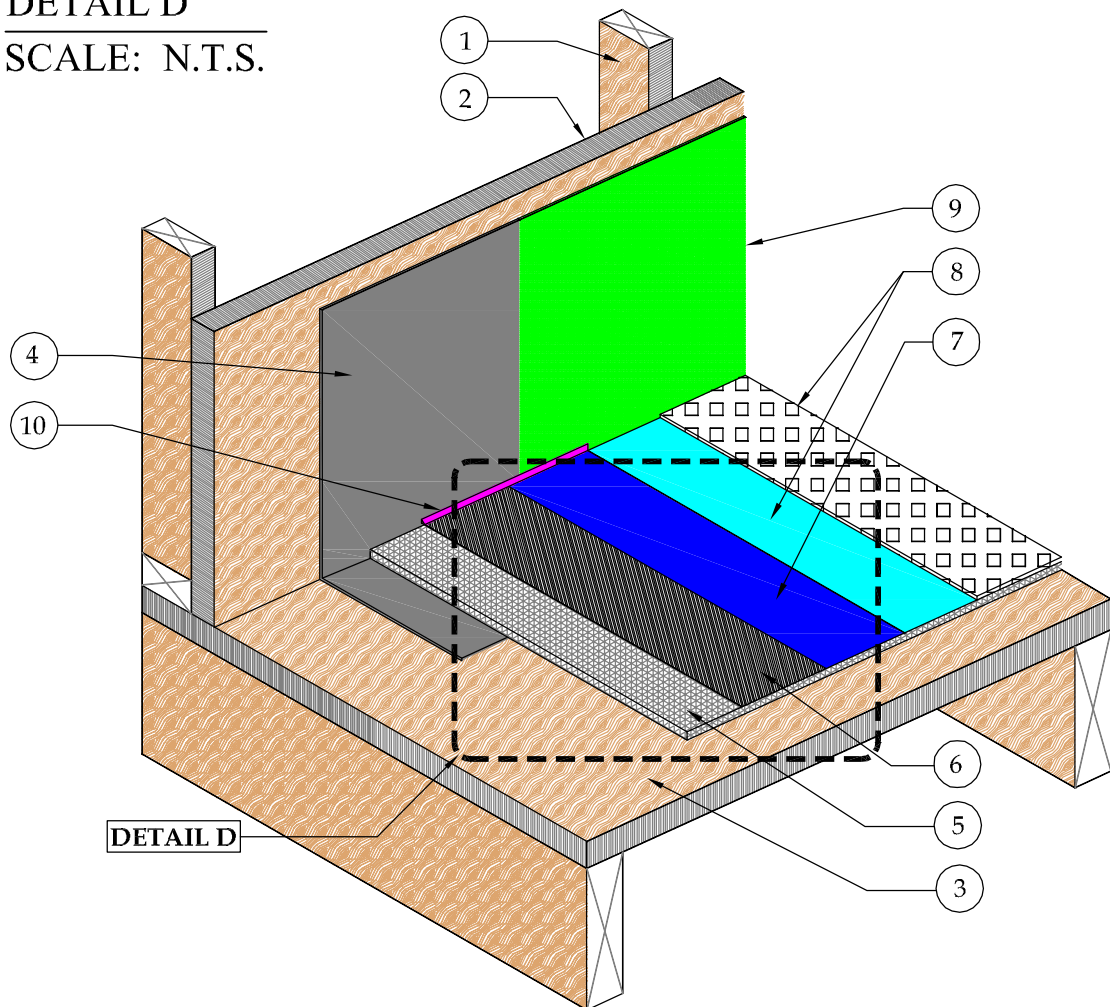

**DETAIL-DECK TO WALL FLASHING DETAIL**

SCALE: N.T.S.



41610 Date St., Suite 104 \* Murrieta, CA. 92562  
 Phone: 800.364.0287 \* Fax: 951.834.9555  
 WWW.PLIIDEK.COM

These waterproofing procedures are not to be used for permit and should be reviewed by the project architect. The waterproofing procedures are not complete plans or specifications and a professional design professional should be contacted prior to performing major waterproofing and repairs.

HD-250 by Pli-Dek System, Inc.

DECK TO WALL FLASHING DETAIL

Job:		Drawing Number: <b>HD-3</b>
Date:	09-01-2013	
Dwn:	H.K	